

Data transmission of delivery and transport data

VDA 4913

Version 4, April 1996



Process description

This recommendation regulates the electronic data transfer of

- delivery note and transport data between suppliers and customers
- delivery note, transport data and further material flow information between suppliers, external service providers (ESP) and customers.

Disclaimer

The VDA Recommendations are recommendations that may be freely adopted by anyone. Users are responsible for correct implementation of the recommendations as required on a case-by-case basis.

The recommendations take into account the prevailing technology at the time of publication. Use of the VDA Recommendations does not absolve anyone from responsibility for his/her own actions, and all users act at their own risk. Liability of VDA and those involved in drafting of VDA Recommendations is excluded.

If you notice any errors, omissions or ambiguities in these recommendations, please contact VDA without delay so that these errors can be rectified.

Publisher	Verband der Automobilindustrie e.V. (VDA) Behrenstrasse 35, 10117 Berlin www.vda.de This recommendation was developed by Walther, Jörg
Copyright	Verband der Automobilindustrie e.V. (VDA) Reprint, also in extracts, is only permitted, if the source is stated.
Issue	April 1996
Version	Version 4

Table of contents

1	Short description of the message	5
1.1	Usage and goals.....	5
1.2	Changes to quality and testing requirements.....	7
1.2.1	Edition September 93 to Edition October 94 (V. 03).....	7
1.2.2	Edition October 94 to Edition March 96(V. 04).....	7
2	Delivery note and transport data exchange between suppliers and customers	8
2.1	Short description.....	8
2.2	Program test conditions.....	8
2.2.1	Permitted record types	8
2.2.2	Permitted record type order	9
2.2.3	Notes about record type 712 transport data	11
2.2.4	Notes about record type 715 (packaging material record).....	11
2.3	Valid version number.....	19
2.4	Formal examination of data fields.....	19
2.5	Logical examination of data fields.....	19
2.6	Data sender and data receiver number.....	19
2.7	Control totals	19
2.8	relationship of the EDI data with the shipping documents.....	19
2.8.1	Accompanying documents.....	19
2.8.2	EDI-accompanying document (VDA 4912).....	20
2.8.3	Transport label (VDA 4902).....	20
3	ESP (EDL)-processing: delivery and transport data	21
3.1	Short description.....	21
3.2	Program test conditions between SUPPLIERS, EDL, and CUSTOMERS	23
3.2.1	3.2.1 Valid record types	23
3.2.2	Permitted record type order	24
3.2.3	Record types / Field usages	24
3.2.4	Notes about record type 717 (Single package record).....	26
3.3	Valid version number.....	26
3.4	Formal examination of data fields.....	26
3.5	Logical examination of data fields.....	26
3.6	Customer, supplier, product receiver number	26
3.7	Control totals	26
3.8	Connection DFÜ to shipping documents.....	26

4	Correction procedure, EDI-errors	27
4.1	Data sender information	27
4.2	Data receiver information	27
5	Annexe	28

1 Short description of the message

1.1 Usage and goals

This process description regulates the processing of data transmission of delivery note and transport data and further material flow information via public transmission grids between suppliers, external service providers (EDL), and customers.

This description is kept intentionally universal and independent of hardware. The procedure is usable independently of specific application systems.

This recommendation has two purposes:

1. Exchange of delivery note and transport data between suppliers and customers. It is in use since 1984. →Description see chapter 2
2. Exchange of delivery note, transport data and material flow information between suppliers, external service providers (ESP), and customers → Description see chapter 3

In this context, we refer to the possibility of using the VDA recommendation 4930, stock inventory and stock movement message (ODETTE-Subset of message STOACT).

Objectives

- Faster provision of delivery note data and transport data as advance information (material and transport) for the receiver of goods.
This lowers the amount of necessary inquiries for the suppliers.
- Better transparency of the material flow (information instead of inventory).
- Higher data safety and data quality, which leads to fewer differences between suppliers and invoice data.
- Reduction of acquisition effort of the receiver of goods. which leads to faster processing of incoming goods.
- Simplified and compressed presentation of suppliers with additional usage of EDI-accompanying documents VDA 4912.
- Higher quality for packaging inventory management. Reduced effort for the margin processing.
- Efficient goods receiving process at the receiver in connection with scanning of the barcode transport label VDA 4902.

BASIS of this application are the agreements made in the VDA EDI - work group . It contains the

- specification of uniform record formats (fixed length of 128 digits)
- standardisation of data elements, field lengths, field types, keys/ codes,

that are used as a binding programming basis between the EDI participants.

Standard international or national keys (codes), if available, are used for the messages. Depending on need, they are to be turned into customized keys.

For this EDI the records types 711- 719 were assigned.

The structure of the individual record types including the description of the data elements is to be taken from the enclosed annexes.

All data from a record type that contains personal data is subject to data protection

For financial reasons, the data sets were developed free of redundancy, meaning field contents are only sent once.

Important:

It is to be ensured that the data from message VDA 4913 and the data on the accompanying documents (e.g. shipping order, delivery notes, or EDI accompanying documents, transport labels etc.) match.

Additional to this procedure description, we refer to the VDA/ DIN recommendations

DFÜ	Designation
VDA 4920	Transport order data supplier to forwarder
VDA 4921	Transport tracking data forwarder to customer
VDA 4927	Load carrier account statements and movements
VDA 4930	Stock inventory and stock movements (ODETTE-subset of message STOACT)
Forms	
VDA 4902	Transport label
VDA 4912	Goods accompanying document in DFÜ process
DIN 4994	Delivery note form
VDA 4922 / DIN 5018	Freight order / transport order

Interaction of VDA messages and receipts

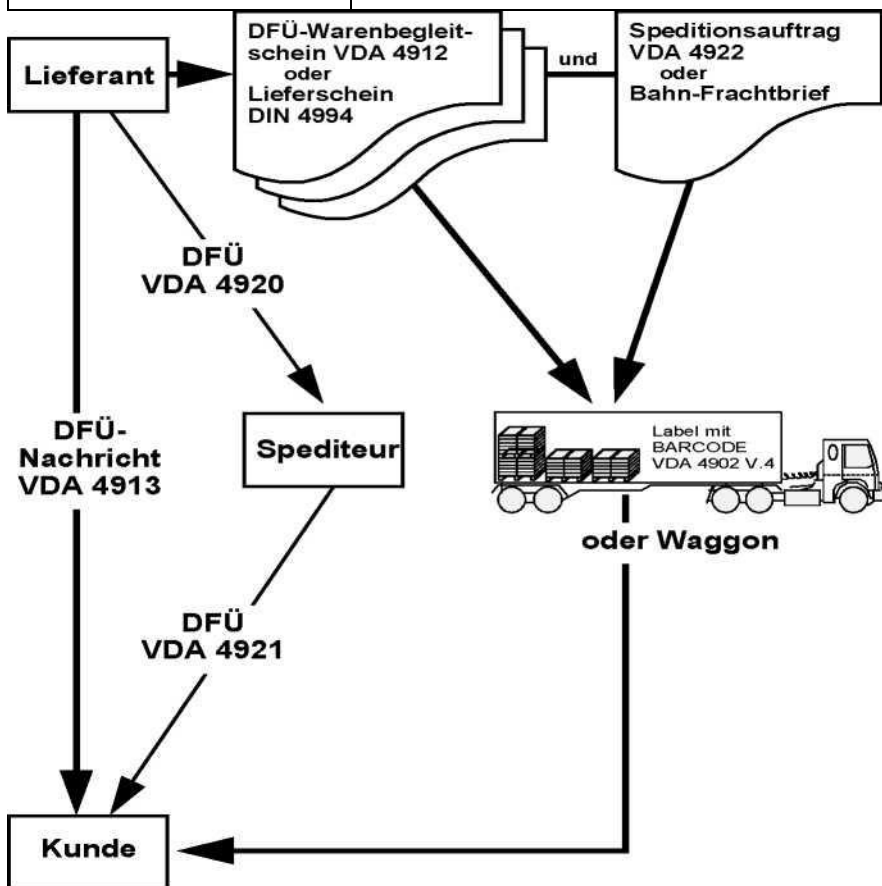

Lieferant = Supplier
DFÜ = EDI

Kunde = Customer
Lieferschein = Delivery note

Spediteur = Forwarder
Speditionsauftrag = Transport order

1.2 Changes to quality and testing requirements

Short description of most important changes:

1.2.1 Edition September 93 to Edition October 94 (V. 03)

Editorial

- Extended description of application of packaging record 715 in connection with the transport label VDA 4902
- Omission of checklists
- Record type 714 delivery note position with new version number 03
- New data element item 22 original delivery note number.
Only relevant for the EDL processing, transaction type 36
 - Record type 715 packaging record with new version number 03
- new data element item 13 label identification
This element creates the connection to the transport label VDA 4902, data element packaging item number.
- new data element item 14 packaging identification
This element sorts the packaging by one-way and reusable.
- new data element item 15 property identification.
This element sorts by ownership: customer, supplier, third parties
 - Code list
- new coded item 11 packaging code related to data element packaging number customer (record type 715, item 03).

1.2.2 Edition October 94 to Edition March 96(V. 04)

Editorial

- Record type 711 attachment with new version number 03
- new data element item 11 DELIVERY IDENTIFICATION
Record type 712 transport record with new version number 03
- Redefinition of data element TARIFF ZONE / COMMUNITY TARIFF Division in two fields (identification and user data field). Here, either the postal code of the place of dispatch or the registration number can be entered.
- Extension item 13 TRANSPORT PARTNER NUMBER , also private parcel services.
Record type 713 delivery note header with new version number 03
- new data element item 20 DOCUMENT NO. CUSTOMER
- Item 06 SHIPPING METHOD extended to key "Private parcel service".
Record type 715 packaging record
- revised description under 2.2.4 in connection with the transport label.

2 Delivery note and transport data exchange between suppliers and customers

2.1 Short description

With this type of processing, for each shipment the data included in the shipping/ freight order, delivery note or transport label is processed by the supplier and directly transferred to the automobile manufacturer or data receiver.

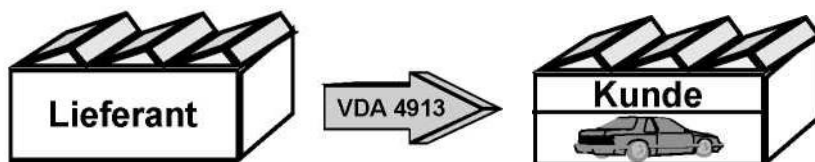

Note:

If no EDI is done in exceptional cases (special transports, late shipment), "no DFÜ" is to be noted in the field EINGANGS- UND BEARBEITUNGSVERMERKE (entry and processing notes).

2.2 Program test conditions

For the data exchange between SUPPLIERS and CUSTOMERS the following test conditions are to be considered. They are in accordance with the regulations of the VDA working group "Vordruckwesen/ Datenaustausch" and documented in the VDA-AKVD data catalogue (VDATABASE).

2.2.1 Permitted record types

Record type	Description	Must/Can
711	Attachment delivery not and transport data (1x per DFÜ run)	Must
712	unique data of the transport (x per shipment)	Must
713	unique data of the delivery note (header data)	Must
714	Delivery note position data	Must
715	Packaging data	Can ¹
716	Text data about position	Can
718	Product number data	Can
719	Postscript delivery note and transport data (1 x each DFÜ – run)	Must

In case of usage of reusable packaging, the record type 715 must be transferred.

In case of usage of one-way packaging, the transfer is to be agreed upon bilaterally.

2.2.2 Permitted record type order

Presentation of record type order / group change:

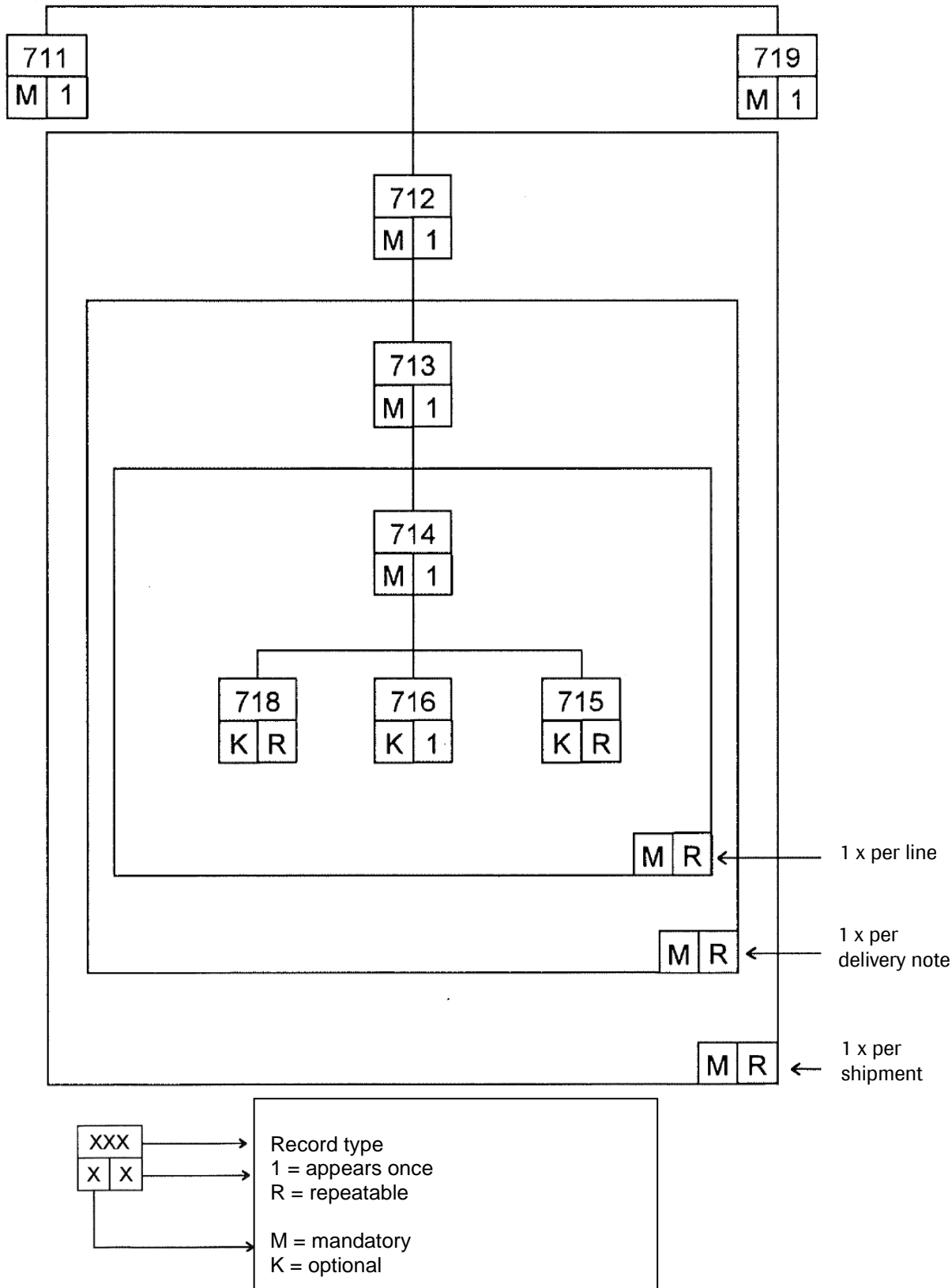

Examples for the structure of a message:

Record type	Must/Can	Content
711	Must	first record of DFÜ
<i>Transport 1</i>		
712	Must	Transport-no. 00000001
713	Must	Delivery note no. 00000100
714	Must	Position record 1
715	Must	Packaging data grid pallet
714	Must	Position record 2
715	Must	Packaging data pallet Y
714	Must	Position record 3
718 ²	Can	Product number data
716	Can	Text about position
715	Must	Packaging data flat pallet Z
715	Must	Packaging data stacking frame
<i>Transport 2</i>		
712	Must	Transport-no. 00000002
713	Must	Delivery note no. 00000200
714	Must	Position record 1
718 ¹	Can	Product number data
714	Must	Position record 2
718	Can	Product number data
714	Must	Position record 3
7182	Can	Product number data
715	Must	Packaging data VDA small load carrier
<i>End user data</i>		
719	Must	last record of DFÜ

¹ Record type 718 is only used for just -in-time deliveries

2.2.3 Notes about record type 712 transport data

(see also VDA-recommendation 4922)

This record type specifies a shipment volume (max. 1 truckload) of a supplier.

The number of record types 712 and the assignment of the SHIPMENT REFERENCE NUMBER corresponds with the transport order. Generally, it is to be differentiated between two variants. The choice of variant is to be agreed bilaterally.

Variant 1: 1 shipment for a delivery address = 1 shipment reference number

Example: Two shipments are loaded on one day

Truck 1:

Delivery Note 021 to 025 → Shipment 00000001

Data sets for truck 1 (excerpt):

Record type 712 shipment reference number	00000001
Record type 713 delivery note numbers	00000021
Record type 713 delivery note numbers	00000022
...	
Record type 713 delivery note numbers	00000025

Truck 2:

Delivery Note 026 to 030 → Shipment 00000002

Data sets for truck 1 (excerpt):

Record type 712 shipment reference number	00000002
Record type 713 delivery note numbers	00000026
Record type 713 delivery note numbers	00000027
...	
Record type 713 delivery note numbers	00000030

Variant 2: 1 truck shipment = n shipment reference numbers

Depending on agreement of the partners, it is also possible to assign multiple shipment reference numbers to one truck load.

For this variant,

→ all delivery notes for one unloading point receive their own shipment reference number, i.e. a new unloading point triggers a new shipment.

More in the data element description.

2.2.4 Notes about record type 715 (packaging material record)

a) General notes

This record type includes data from the package level. It corresponds and connects the package number with the transport label according to the VDA recommendation 4902. The VDA recommendation 4902 must be considered for the DFÜ implementation.

The incoming goods on the package level are increasingly processed by scanning the barcode of the package number on the transport label. This goes with a comparison of the DFÜ data with the record type 715.

The most important shared data elements on the transport label and the DFÜ are

- Supplier number
- LABEL identification: Barcode prefix of the package number
- Package number
- Filling quantity of the package

The record type can further be used to show all the possibilities of different packaging classifications in the data element PACKAGE IDENTIFICATION:

- REUSABLE packages (property of customer or supplier)
- One-way packages
- References to auxiliary packages

The information requirement of data receivers is different. It is therefore to be agreed bilaterally to which extend packages are to be presented in the DFÜ.

Besides the group changes resulting from the record type order, a change to the next record type 715 is required, if one of the conditions is reached:

- Change of PACKAGE NUMBER CUSTOMER
- Change of filling quantity
- PACKAGE NUMBERS do not rise without gaps.

Note:

In case of consecutive number assignment, there is the possibility to use the data elements PACKAGE NUMBER FROM and PACKAGE NUMBER TO (only valid with label identification 'S').

b) Data element PACKAGE NUMBER CUSTOMER

This data element indicates the coding that was agreed between the partners.

For one-way packaging or rented packaging from third parties, there is a coding suggestion in the key registry annex 10, position 11. Before using DFÜ, its usage is to be coordinated with the partners.

c) Quantity plausibility test:

Delivery note position amount and package filling quantity

All packaging details (record type 715) must be subsequently transferred to a delivery note position (record type 714). The filling quantity details in the record type 715 must match the quantity specified in the delivery note position in case of a multiplication/ addition.

Example:

Record type	Packaging no. Customer	Number Packaging	Filling quantity (each package)
715	2032	14	100
715	2032	1	63

The delivery note position amount (record type 714) must be in this example 1463.

d) Transport label VDA 4902 and packaging record type 715

General specifications:

On the TRANSPORT LABEL VDA 4902 in the barcode prefix of the data element PACKAGE NUMBER there is a LABEL IDENTIFICATION put in front. This identification controls the filling (per pack) quantity in the record type 715.

There are the following prefix possibilities:

- S = single: The package only contains an item number. Indication of the filling quantity is required. If load units are only presented with a single label: Indication of filling quantity of all stacked containers as a sum value. See example 3b
- M = master: The indication of filling quantity in the record type is omitted (filling value = ZERO). See example 3a

- G = mixed: The package contains multiple item numbers.
The indication of filling quantity in the record type 715 is omitted (filling value = ZERO)
The usage of a 'G' label is only allowed in connection with single labels. See examples 2, 4

Whether for loading units

- a master label must be used together with a single label or
- only a single label with the added filling quantity of the loading unit must be agreed by the partners.

For each enclosed shipment, there is usually one packaging record for each delivery note position.

- "Main" delivery note position
 1. A1) Content PACKAGING NUMBER CUSTOMER , QUANTITY of PACKAGES, LABEL IDENTIFICATION
 2. B1) Content PACKAGING NUMBER CUSTOMER then has the keyword content COPACK, the FILLING QUANTITY indication, LABEL IDENTIFICATION = S
- Assigned COPACK position(s)
For the 2nd and further delivery note positions, in the packaging record:
 1. A2 ff) the data element PACKAGING NUMBER CUSTOMER and the PACKAGE NUMBER is repeated.in the data element AMOUNT PACKAGING however, the amount ZERO will be indicated during the repetition (identification feature for a correct packaging inventory management).
 2. b2 ff) as described under b1. o See example 2

For loading unit accessory such as covers, there are no TRANSPORT LABELS.

A record type 715 is still necessary for those parts because of the automatic booking for the packaging inventory management, but without indication of a PACKAGE NUMBER and without LABEL IDENTIFICATION.

Loading units (LE)

The master label with PACKAGE- NUMBER and LABEL IDENTIFIATION is assigned to the sub-pallet (data element PACKAGING CUSTOMER).

Record types order:

For the presentation of the LE, the previously described record is to be transferred as 1. Record type

Example 1: Load carries without sub-pallet e.g. grid pallets "item number clear

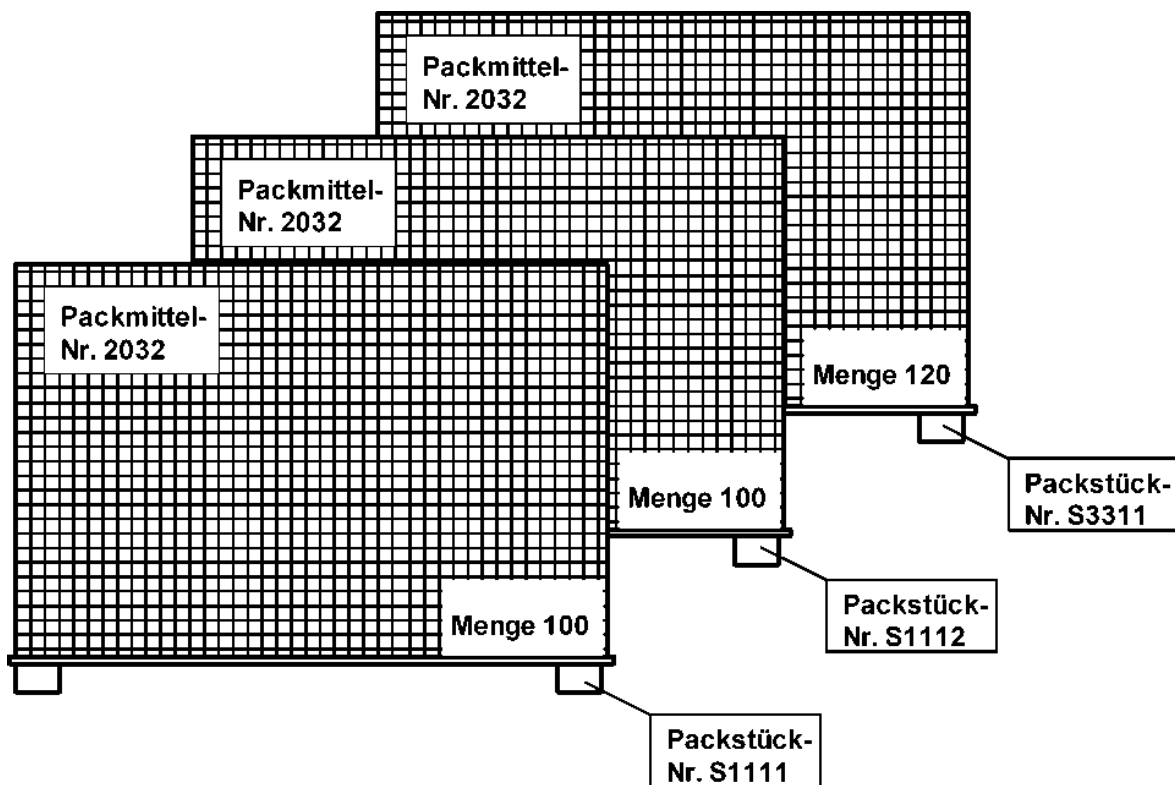

Packmittel = Package type code

Menge = Quantity

Packstück-Nr. = Package number

Coding (excerpt)

Record type 713; Delivery note number 12345678					
Record type 714 (Item 001); item number 4711; delivery amount 320					
Record type 715					
Packaging number Customer M/A	Number Packaging M/N	Filling quantity K/N	Package from K/A	Package to K/A	Label Identification K/A
2032	0000000000002	0000000000100	1111	1112	S
2032	0000000000001	0000000000120	3311	□□□□	S

Example 2: Load carrier without sub-pallet with multiple item numbers (mixed shipment in 1 packaging)

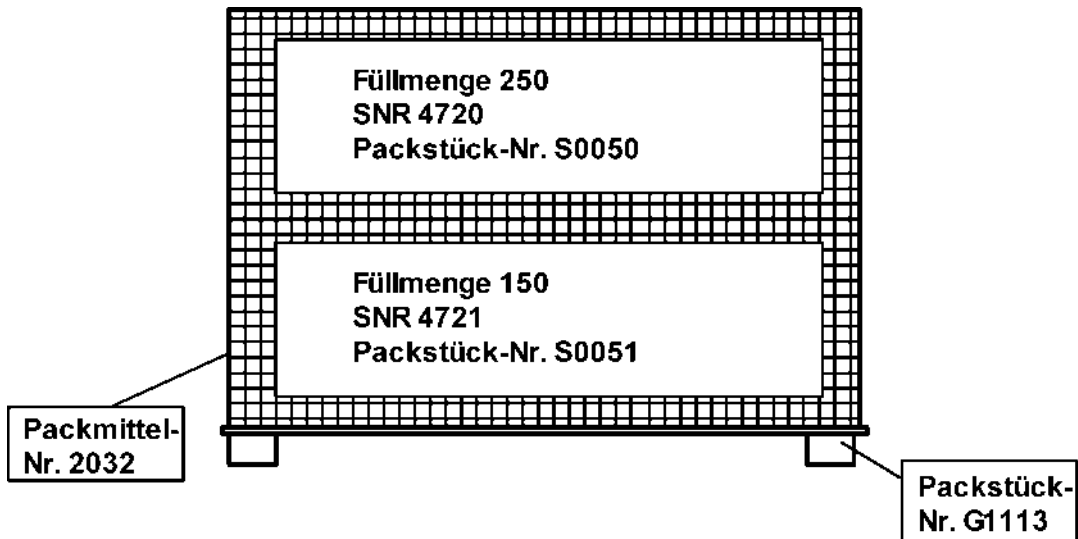

- Füllmenge = Quantity per pack
- SNR = Part number
- Packmittel = Package type code
- Packstück-Nr. = Package number

Record type 713 Delivery note number 12345678					
Record type 714 (Item 001); item number 4720; delivery amount 250					
Record type 715					
Packaging number Customer M/A	Number Packaging M/N	Filling quantity K/N	Package from K/A	-Number to K/A	Label Identification K/A
2032	0000000000001	0000000000000	1113	□□□□	G
Enclose	0000000000001	0000000000250	0050	□□□□	S

Record type 714 (Item 002); item number 4721; delivery amount 150					
Record type 715					
2032	0000000000000	0000000000000	1113	□□□□	G
Enclose	0000000000001	0000000000150	0051	□□□□	S

Example 3a: Load unit "item number clear" with transport label for each single container

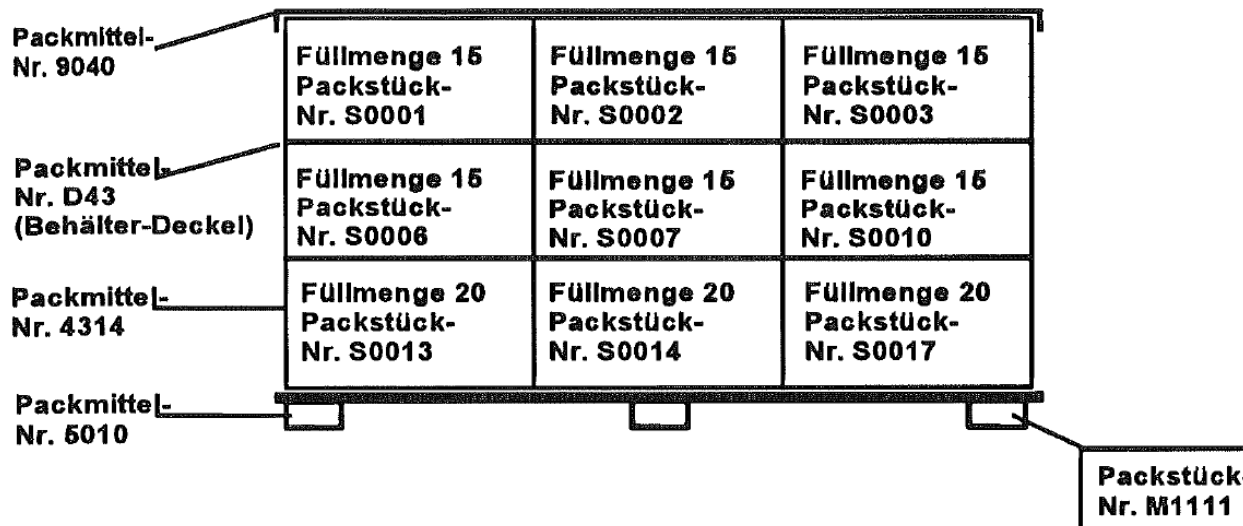

Packmittel-Nr = package type code
 Füllmenge = quantity per pack / filling quantity
 Packstück-Nr = package ID

Coding (excerpt)

Record type 713 Delivery note number 12345679					
Record type 714 (Item 001); item number 4712; delivery qty 150					
Record type 715					
Packaging number Customer M/A	Number Packaging M/N	Filling quantity K/N	Package -number from K/A	number to K/A	Label Identification K/A
5010	0000000000001	0000000000000	1111	□□□□	M ²
4314	0000000000003	0000000000015	0001	0003	S
4314	0000000000002	0000000000015	0006	0007	S
4314	0000000000001	0000000000015	0010	□□□□	S
4314	0000000000002	0000000000020	0013	0014	S
4314	0000000000001	0000000000020	0017	□□□□	S
D43	0000000000009	0000000000000	□□□□	□□□□	□□□□
9040	0000000000001	0000000000000	□□□□	□□□□	□□□□

Notes about Transport label:

Lids do not get a transport label, but must be transferred in the record type 715 (because of the load carrier inventory management).

Example 3b: Loading unit "item number clear" with transport label for each load unit

² On the master label, according to VDA recommendation, the total amount of all stacked containers on the lead unit is to be printed out. Here in the VDA 4913, record type 715, the filling quantity is to be indicated = Zero. The record type is to be transferred as shown above.

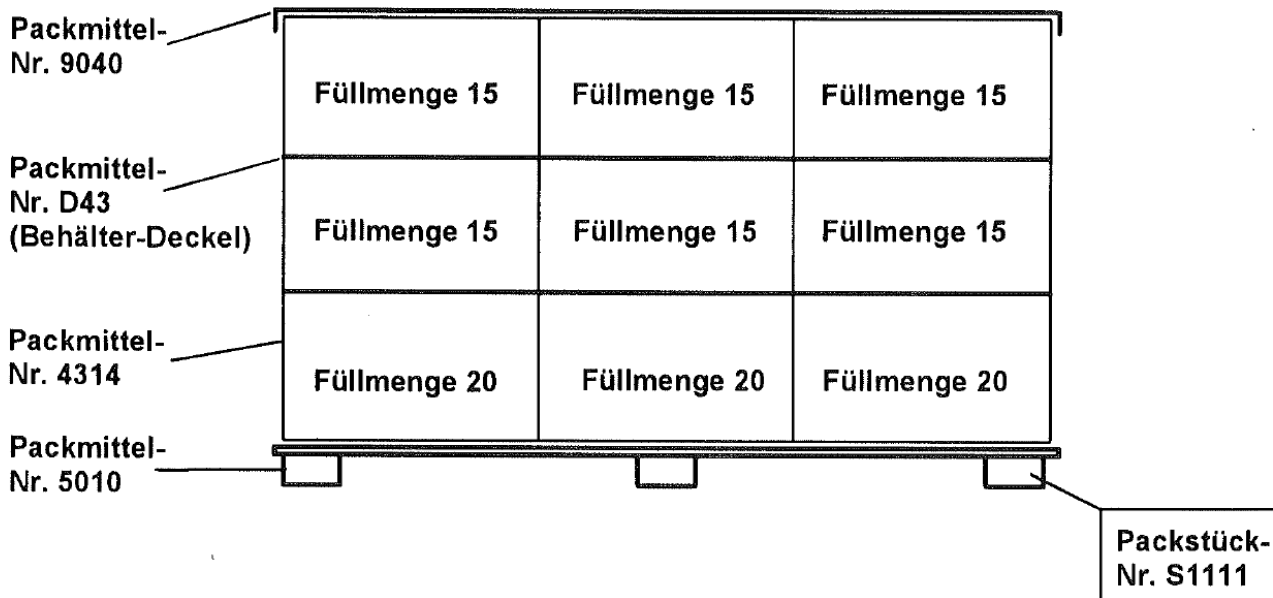

Packmittel-Nr = package type code,
 Füllmenge = quantity per pack / filling quantity
 Packstück-Nr = package ID

Coding (excerpt)

Record type 713 Delivery note number 12345679					
Record type 714 (Item 001); item number 4712; delivery amount 150					
Record type 715					
Packaging number Customer M/A	Number Packaging M/N	Filling quantity K/N	Package -number from K/A	to K/A	Label Identification K/A
5010	0000000000001	0000000000150	1111	□□□□	S
4314	0000000000009	0000000000000	□□□□	□□□□	□□□□
D43	0000000000009	0000000000000	□□□□	□□□□	□□□□
9040	0000000000001	0000000000000	□□□□	□□□□	□□□□

Example 4: Loading with 3 different part numbers, individual package are filled homogeneously (i.e. one part number per individual package)

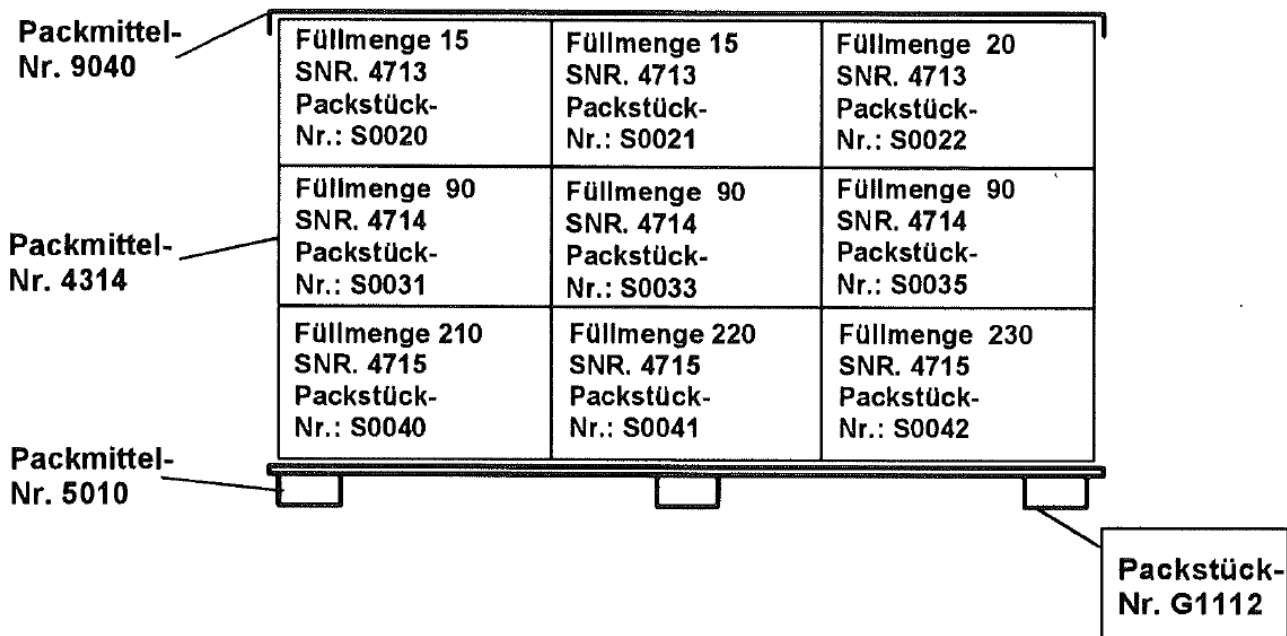

Coding (excerpt)

1.1

Record type 713 Delivery note number 12345679					
Record type 714 (Item 001); item number 4713; delivery qty 50					
Record type 715					
Packaging number Customer M/A	Number Packaging M/N	Filling quantity K/N	Package from K/A	Package number to K/A	Label Identification K/A
5010	0000000000001	0000000000000	1112	□□□□	G
4314	0000000000002	0000000000015	0020	0021	S
4314	0000000000001	0000000000020	0022	□□□□	S
9040	0000000000001	0000000000000	□□□□	□□□□	□□□□
Record type 714 (Item 002); item number 4714; delivery amount 270					
Record type 715					
5010	0000000000000	0000000000000	1112	□□□□	G
4314	0000000000001	0000000000090	0031	□□□□	S
4314	0000000000001	0000000000090	0033	□□□□	S
4314	0000000000001	0000000000090	0035	□□□□	S
Record type 714 (Item 003); item number 4715; delivery amount 660					
Record type 715					
5010	0000000000000	0000000000000	1112	□□□□	G
4314	0000000000001	0000000000210	0040	□□□□	S
4314	0000000000001	0000000000220	0041	□□□□	S
4314	0000000000001	0000000000230	0042	□□□□	S

2.3 Valid version number

The version number used by the data admin of each record type must match the version number to be processed at the receiver.

A change of version number must be agreed in good time by the DFÜ participants before the starting date. The agreement must be made for each customer number. This especially applies to companies with multiple locations that are organised decentralised and are therefore possibly using different software.

It is recommended to agree upon the most recent version. At most the previous version should be agreed upon.

2.4 Formal examination of data fields

All data fields of a record type must be in accordance with the formal provisions administered by the VDA data catalogue.

Numerically defined fields are to be regarded as decimal and filled right-justified with leading zeros. If the fields are not used, they are to be filled with zeros.

Alphanumerically defined fields (in case of non-usage) must be filled with blanks.

2.5 Logical examination of data fields

Individual examinations are chosen from different record types to ensure that the right DFÜ participant receives the correct data.

2.6 Data sender and data receiver number

The connection between data sender and receiver number used in the record type 711 must match the number registered at the receiver.

2.7 Control totals

The sums determined in the records type 719 (numerical fields each record type must match the transferred records for each record type).

If an error is found in the aforementioned examinations, the DFÜ is to be repeated completely.

2.8 relationship of the EDI data with the shipping documents

2.8.1 Accompanying documents

a) Street: Consignment note / Shipping order (VDA 4922 or DIN 5018)

The following information is required on the consignment note/ shipping order (see VDA recommendation 4922), because they are required as defining arguments for the receipt of goods to determine the DFÜ data:

- Supplier number (data sender from record type 711)
- Shipment reference number (from record type 712)

There are to versions of a consignment note issue:

1. One consignment note/ shipping order per each shipping address

On this consignment note / shipping order, **all** unloading points of a shipping address are

summarized. However, if multiple external warehouses are to be driven to for one receiver, they are to be considered separate shipping addresses.

2. One consignment note/ shipping order each unloading point.

For 3 unloading points, 3 consignment notes/ shipping orders are required.

The required variant is to be coordinated with the receiver of goods.

For the assignment of the shipment reference number applies that for each issued consignment note/ shipping order, one number is to be assigned.

b) Rail: Train consignment note

On the train consignment note, the supplier number and shipment reference number are to be entered into the field

“(21 Für die Eisenbahn unverbindliche Absendervermerke (8)” as follows:

Supplier no.: 123456789

Shipment no.: 12345678

The delivery note numbers can be entered into the field H).

2.8.2 EDI-accompanying document (VDA 4912)

To reduce the amount of paper, it is highly recommended to use the DFÜ accompanying document according to VDA recommendation 4912 instead of the delivery note according to DIN 4994.

2.8.3 Transport label (VDA 4902)

A detailed description can be found under 2.2.4.

3 ESP (EDL)-processing: delivery and transport data

3.1 Short description

This description regulates the exchange of shipping order, delivery note and further material flow information for the management of supplier storages by third parties (external service providers EDL). The delivery of the shipments is not done directly at the customer (automobile manufacturer), but an external service provider (EDL).

Alternatively to this message, the message VDA 4930 (German translation of the ODETTE-message STOACT) can be utilized. The description is available at the VDA.

The choice of message type is to be agreed on by the EDL-partners.

Information exchange with external service provider centres (EDL)

a) Information flow

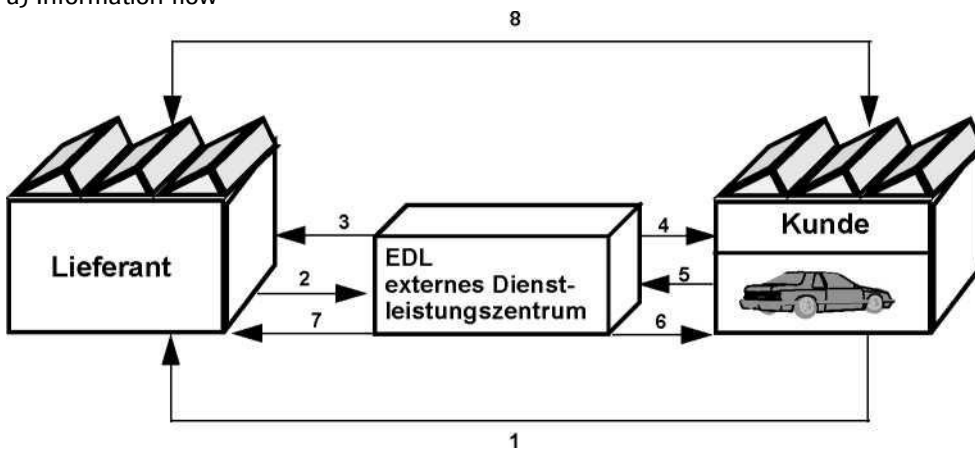

- 1 = Delivery instruction VDA 4905 or detailed call-off VDA 4915
- 2 = delivery note transport data VDA 4913 supplier to EDL
- 3 = confirmation of receipt EDL to supplier VDA 4913
- 4 = inventory information EDL to customer VDA 4913
- 5 = warehouse status customer to EDL
- 6 = Delivery note data EDL to customer VDA 4913 and relocation information EDL to supplier VDA 4913
- 7 = inventory
- 8 = invoice data according to VDA 4906 supplier to customer or credit note VDA 4908 customer to supplier

b) Booking procedures (record type 713)



Transaction Type	Booking	Receiver
------------------	---------	----------

30	Report of receipt	Supplier
32	Transport damages/loss/difference	Supplier
33	Return shipment	Supplier
35	Inventory report	Supplier / customer
36	Dispatch notes	Supplier
40	Delivery advice	EDL / customer

There are three different ways of communication. The following transaction types can be made in the record type 713:

- a. Supplier to EDL = delivery advice (transaction key 40)
- b. EDL to supplier
 - = report of receipt (transaction key 30)
 - = transport damages/loss/difference (transaction key 32)
 - = return shipment (transaction key 33)
 - = inventory declaration (transaction key 35)
 - = dispatch notice (transaction key 36)
- c. EDL to customer
 - = delivery advice (transaction key 40)
 - = inventory declaration (transaction key 35)

The usage of the different procedure types is to be agreed on between the partners.

3.2 Program test conditions between SUPPLIERS, EDL, and CUSTOMERS

3.2.1 3.2.1 Valid record types

Record type	Description	Must/Can
711	Attachment delivery not and transport data (1x per EDI)	Must
712	Data of the transport (1 x each shipment)	Must
713	unique data of the delivery note (header data)	Must
714	Delivery note position data	Must
715	Packaging data	Can ³
716	Text data about position	Can
717	Single package data	Can
718	Product number data	Can
719	Trailer record (1 x each DFÜ-run)	Must

³

In case of usage of reusable packaging, the record type 715 must be transferred. In case of usage of one-way packaging, the transfer is to be agreed upon bilaterally.

3.2.2 Permitted record type order

Presentation of record type order / group change for the EDL-processing:

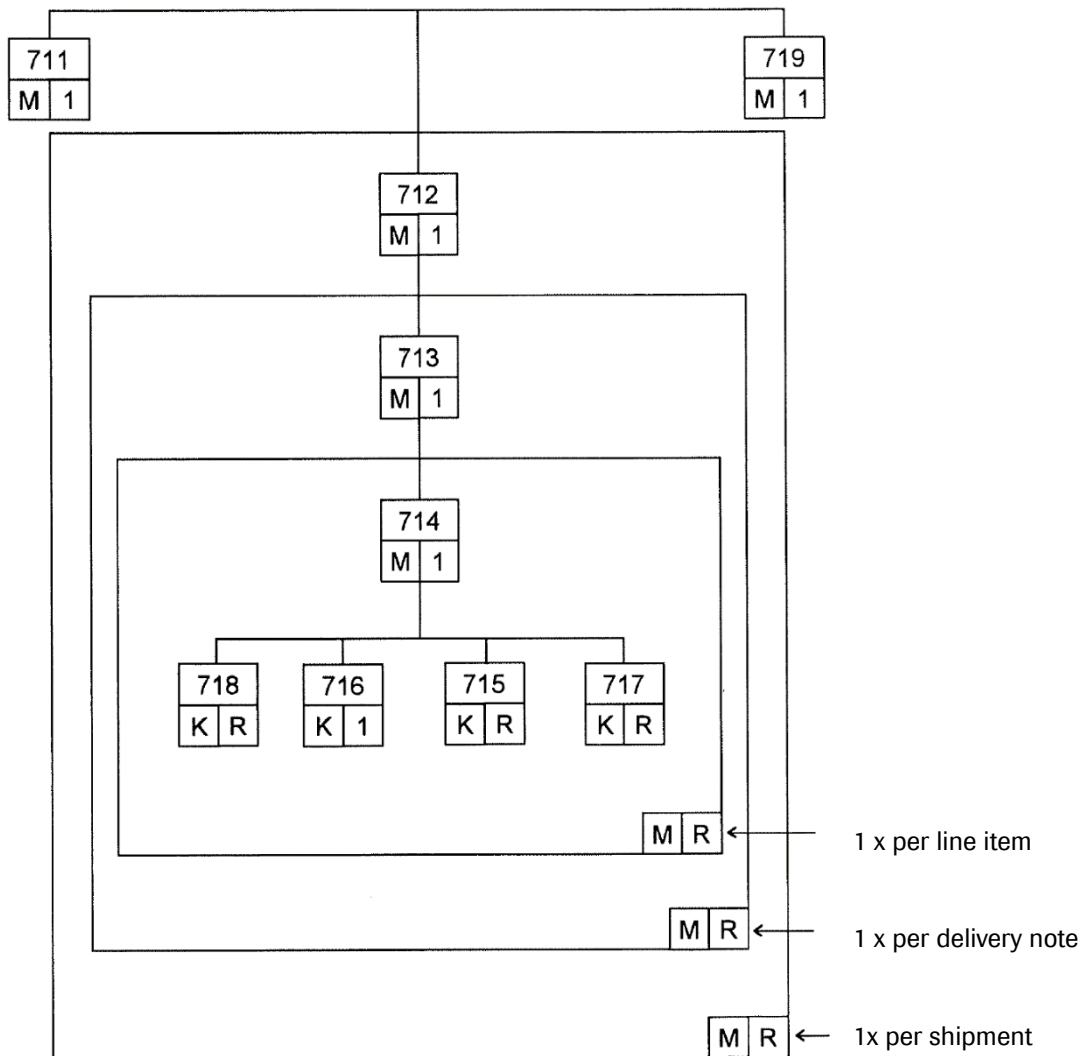

3.2.3 Record types / Field usages

In this list, all record types and data fields that may occur in connection with the EDL-communication are presented **transaction-based**. There, the data fields used for each procedure type in the record type 713 count as must-fields (possibly deviating from specifications according to annex 1-9).

Report of goods receipt to supplier

Transaction key 30

Record type	Data field	
711	1-7, 10	
712	1, 2	
713	1-4, 9, 16	
714	1-4, 6, 7, 8, 9, 12	O = optional
715	Optional, if used, then 1-6	
717	Optional, if used, then 1-5, 6,7	
719	Complete	

Transport damages/loss/difference to supplier

Transaction key 32

Record type	Data field	
711	1-7, 10	
712	1-2	
713	1-4, 9, 16	
714	1-4, 6, 7, (8-9), 12	O = optional
715	Optional, if used, then 1-6	
717	Optional, if used, then 1-5, 6,7	
719	Complete	

Return delivery to supplier

Transaction key 33

Record types and content as procedure 32.

Inventory information to supplier / customer

Transaction key 35

Record type	Data field	
711	1-7, 10	
712	1-2	
713	1, 2, 4, (5), 9, 13, 16	O = optional
714	1-4, 6, 7, 8, 9, 20	
717	Optional, if used, then 1-5, 6,7	
719	Complete	

Dispatch notice to supplier

Transaction key 36

Record type	Data field	
711	1-7, 10	
712	1-2	
713	1-5, 9, 11, 13	
714	1-4, 6, 7, 8, 9, 12, 22	
715	Optional, if used, then 1-6	
717	Optional, if used, then 1-5, 6, 7	
719	Complete	

Advice of delivery to EDL / customer

Transaction key 40

Record type	Data field
711	According to annex 1, if EDL to customer additionally 10
712	According to annex 2
713	According to annex 3, additionally 9 and 16.
714	According to annex 4, If record type 717 is used, the delivery quantity of record type 714 must be equal to the sum of delivery quantities of all record types 717 of this line item
715	Optional
716	Optional
717	Optional, if used, then 1-7
719	Complete

3.2.4 Notes about record type 717 (Single package record)

The record type 717 is an optional record. It is required, if the inventory management is done on package / coil level. Then for each single packaging item / coil number a record must be transmitted.

3.3 Valid version number

see description under 2.3

3.4 Formal examination of data fields

see description under 2.4

3.5 Logical examination of data fields

see description under 2.5

3.6 Customer, supplier, product receiver number

The connection between data sender and receiver number used in the record type 711 must match the number registered with the receiver.

Are to be agreed on between supplier and EDL or EDL and customer.

In record type 713, the customer number agreed between supplier and customer is to be transferred to the field receiver number and the supplier number in the field supplier number.

3.7 Control totals

see description under 2.7

3.8 Connection DFÜ to shipping documents

see description under 2.8

4 Correction procedure, EDI-errors

4.1 Data sender information

- a. In case of corrections to already performed DFÜ, the data or goods receiver is to be informed immediately via telefax or email.
If possible, a copy of the corrected receipt is to be added.
- b. Alternative correction options are only valid upon bilateral agreement:
To reduce the manual effort of the receiver, the corrected data can be transferred again with a new shipment reference number.

4.2 Data receiver information

If errors in the transmission file are noticed by the receiver, it is recommended to immediately notify the sender via telefax or email.

The information should contain the following statements:

- Sender with department, editor, telephone and telefax number
- DFÜ-number, date
- Shipment reference number
- Delivery note number
- Record type
- Data element and actual content (wrong)
- Data element and intended content (right, as far as known)
- verbal description of the claim.

5 Annexe

Structure description of record type

711

Version

03

Header record of the transmission

Once per transmission

DE	Data Element Name	St	P	F	Data Element Description
711_01	Record type	M	1	N3	<i>Constant "711", must be present once each interchange</i>
711_02	Version no.	M	4	N2	<i>Entry = 03 Identification of the actuality of a record type. Is kept without gaps for each record type and raised by 1 for each change agreed by the VDA work group</i>
711_03	Data Receiver ID / Customer ID	M	6	A9	<i>Identification number that the data sender agrees on with the data receiver.</i>
711_04	Data Sender ID / Supplier ID	M	15	A9	<i>Identification number that the data receiver agrees on with the data sender.</i>
711_05	Old (previous) transmission no.	M	24	N5	<i>Description see transfer number new. For the first transfer, the transfer number old = 00000. Right-justified entry with leading zeros.</i>
711_06	New transmission no.	M	29	N5	<i>The data administrator assigns within an application (e.g. delivery instructions-DFÜ, invoice-DFÜ etc.) for every DFÜ data communication job a transfer number (new). The value "00000" may not be used. Data creator and receiver keep this number until the next transfer of the same application. Since the data administrator also indicates the former transfer number (as number-old) with the new one within this application, the receiver can check the completeness of the DFÜ-inventory for each application. This is why a number sequence rising without gaps is required. Right-justified entry with leading zeros. Examples for entries in both transfer number: No-OLD No-NEW Start: 00000 00001 or: 00000 00017 on-going: 00019 00020 or: 88051 88061 Overflow: 99999 00001 or: 89361 00011</i>
711_07	Transmission date	M	34	N6	<i>Right-justified entry with leading zeros. No decimal digit Form: YYMMDD</i>
711_08	Sub-supplier ID	K	40	A9	<i>Identification number that the customer assigns to the sub supplier.</i>
711_09	Carrier ID	K	49	A9	<i>Shipment information receiver number of transport order (e.g. message VDA 4920). If applying, the content will generally be the same as the field content in the record type 712. Item 13.</i>
711_10	Message origin, code	K	58	A1	<i>Coded, see code list 12 Blank = EDI created by supplier 1 = EDI created by EDL S = EDI created by haulage</i>
711_11	Type of delivery, code	K	59	A1	<i>Usage has to be agreed upon mutually, see code list 13 Blank = Standard J = JIT-delivery E = Express-delivery</i>

DE	Data Element Name	St	P	F	Data Element Description
711_12	Empty	M	60	A69	<i>Filled with BLANKS</i>

Structure description of record type
Unique data of the transport
Once per consignment

712 Version 03

DE	Data Element Name	St	P	F	Data Element Description
712_01	Record type	M	1	N3	<i>Constant "712"</i>
712_02	Version no.	M	4	N2	<i>Entry = 03</i>
712_03	Shipment Load Reference Number (consignment number)	M	6	A8	<i>Reference number that the sender assigns to the shipment; right-justified entry with leading zeros. Repetition of number is not allowed within one year. The following restrictions are to be considered, when the shipment number is generated by sender. Structure of the reference number for shipping orders at each unloading point: If at one loading, multiple shipping orders are created (every unloading point gets a separate shipping order), the structure is as follows: Position 1 to 6 must be identical on all shipping orders for each loading. Positions 7 to 8 for the counting number for each issued shipping order of a loading. Example 1 loading with 3 shipping orders: 1. Order for unloading point 361: SLB-NO 12345601 2. Order 460: SLB-NO 12345602 3. Order 910: SLB-NO 12345603 Entry of no. on the accompanying documents.: o shipping order. VDA4922/DIN 5018 in field 8 o standard railway consignment note 13A.</i>
712_04	Plant supplier	K	14	A3	<i>Plant of the supplier, from which it is delivered. Encoded form of the supplier.</i>
712_05	Carrier	M	17	A14	<i>Name and/or number of the participant that carries out the transport, similar TDED 3126</i>
712_06	Date when goods have been handed over to carrier	M	31	N6	<i>Date of transfer of the shipment to the carrier / haulage. Form: YYMMDD</i>
712_07	Time when goods have been handed over to carrier	M	37	N4	<i>Time of transfer of the shipment to the carrier / haulage. Format: HHMM</i>
712_08	Shipment gross weight	M	41	N7	<i>Weight of goods including packaging and/or loading tools, but not including containers of the carrier (indication from consignment note), similar TDED 6292; quantity unit = kg, right-justified entry with leading zeros, no decimal digit. The field content must match the indicated weight from the consignment note.</i>
712_09	Shipment net weight	K	48	N7	<i>Weight of goods including packaging without loading tools and containers of the carrier, similar TDED 6110; quantity unit = kg, right-justified entry with leading zeros, no decimal digit.</i>
712_10	Delivery terms, coded	K	55	N2	<i>Indicates, who has to pay shipment costs and to what extend. Encoded form, see separate code list.</i>
712_11	Carrier transmission indicator	K	57	A1	<i>Encoded form: 1 = transport-EDI according to VDA 4920 to carrier has taken place. In this case the carrier number (record type 711, item 09) must be filled out.</i>
712_12	Number of packages	K	58	N4	<i>Sum of all packages in the shipment that are handled. Example: 1 loading unit = 1 package right-justified entry with leading zeros, no decimal digit.</i>

DE	Data Element Name	St	P	F	Data Element Description
712_13	Transport partner ID	K	62	A14	<i>Identification number (max. 9 digits) of the assigned carrier / private parcel service chosen by the customer. If the transport is not carried out by a company assigned by the customer, the name of the carrier is entered here.</i>
712_14	Means of transport, coded	M	76	N2	<i>See separate code list</i>
712_15	Means of transport number	M	78	A25	<i>Indication of detailed designation or number for the means of transport named in the previous field. If the transportation key 01 LICENCE PLACE is used, the official license plate of the tractor unit and/or trailer/semi-trailer or the swap body number must be indicated. Multiple registration numbers are separated by 1 blank. If the T key 02 is used for the BORDERO NUMBER, the license plate can be entered in the field 17 (identification in field 16 is then = 2).</i>
712_16	Qualifier for information in record 712, field 17	K	103	A1	<i>Encoded form: 1 = In field 17, the postal code (of the street address) of the shipping plant for the load determination is entered. 2 = In field 17, the official license plate of the transport vehicle (tractor unit) is entered. The entry is only valid if in field 14 the value 02 (for BORDERO number) is entered.</i>
712_17	Content in accordance with the qualifier in 712, field 16	K	104	A8	<i>see description field 16.</i>
712_18	Required arrival date	K	112	N6	<i>Date specified by the customer, on which the shipment shall arrive. Form: YYMMDD</i>
712_19	Required arrival time	K	118	N4	<i>Time specified by the customer, on which the shipment shall arrive. Form: HHMM</i>
712_20	Loading meters	K	122	N2,1	<i>Indication of used meters of loading area, 1 decimal digit</i>
712_21	Truck type code	K	125	N1	<i>See separate code list</i>
712_22	Empty	M	126	A3	<i>Filled with BLANKS</i>

Structure description of record type 713 Version 03
 Unique data of the delivery note (header information)
Once per delivery note

DE	Data Element Name	St	P	F	Data Element Description
713_01	Record type	M	1	N3	<i>Constant "713"</i>
713_02	Version no.	M	4	N2	<i>Entry = 03</i>
713_03	Delivery note number	M	6	N8	<i>Identification number that the supplier assigns to the delivery note, right-justified entry with leading zeros. Must not be repeated within a year. EDL-application: - Transaction key 30 (report of receipt): Number of supplier. - Transaction key 32 (Transport damages / loss / difference): Number of supplier, if specific assignment is possible. - Transaction key 33 (return delivery): Number of supplier. - Transaction key 35 (inventory declaration): Entry = "00000000" - Transaction key 36 (dispatch notice): Number of EDL to customer. Delivery note numbers must be agreed upon with the supplier. The number issued here is the base for the settlement and coordination between supplier and customer. - Transaction key 40 (Delivery advice): Number of supplier (supplier or EDL)/ number of EDL (EDL or customer, see also procedure 36)</i>
713_04	Despatch date	M	14	N6	<i>Form: YYMMDD EDL-application: on the date of each procedure (dispatch, delivery, inventory date).</i>
713_05	Unloading point	M	20	A5	<i>Indicates the place in the plant of customer, on which the goods shall be unloaded. Coded according to customer's specifications.</i>
713_06	Dispatch type	M	25	N2	<i>see separate code list</i>
713_07	Customer's reference as transmitted in the delivery instruction	K	27	A4	<i>Usually the ID of customer's materials manager / dispatcher</i>
713_08	Contract/Order no.	K	31	A12	<i>Identification number that the customer assigns to a framework agreement / order. Must -field if transmitted in delivery instructions / detailed call-off.</i>
713_09	Process code	K	43	N2	<i>Only filled in case of ESP-process, see separate code list.</i>
713_10	Empty	M	45	A4	<i>Filled with BLANKS</i>
713_11	Customer plant	M	49	A3	<i>Plant of customer, to which shall be delivered. Encoded form of customer.</i>
713_12	Consignment reference	K	52	N8	<i>Reference of consignment delivery note number of customer. Right-justified entry with leading zeros</i>
713_13	Goods receiver ID	K	60	A9	<i>Identification number that the customer assigns to a receiver of goods whose shipping address deviates from the customer's. In case of EDL transaction: see description under 3.6</i>
713_14	Empty 2	M	69	A1	<i>Filled with BLANKS</i>
713_15	Ship to's / Customer's storage location	K	70	A7	<i>Can be individually set by the customer; left-justified entry</i>

DE	Data Element Name	St	P	F	Data Element Description
713_16	Supplier ID	M	77	A9	<i>Only used in ESP-processes: Identification number that the customer assigns to a supplier; left-justified entry.</i>
713_17	Point of consumption / internal destination	K	86	A14	<i>Indicates the point in the plant of the customer, at which the goods are used; alphanumeric without blanks; left-justified entry.</i>
713_18	Call off number	K	100	A4	<i>Number of delivery call-off in case of single orders; left-justified entry.</i>
713_19	Customer's reference as transmitted in an individual order	K	104	A6	<i>Data from the single order</i>
713_20	Document number assigned by customer	K	110	A14	<i>Document number, assigned by customer for this delivery. Corresponds with supplier's delivery note number.</i>
713_21	Empty	M	124	A5	<i>Filled with BLANKS</i>

Structure description of record type

714

Version

03

Delivery note line item data

n times per delivery note

DE	Data Element Name	St	P	F	Data Element Description
714_01	Record type	M	1	N3	<i>Constant "714"</i>
714_02	Version number	M	4	N2	<i>Entry = 03</i>
714_03	Customer's article number	M	6	A22	<i>Identification number that the customer assigns to an article or another service.</i>
714_04	Supplier's article number	M	28	A22	<i>Identification number that the supplier assigns to an article or another service.</i>
714_05	Country of origin, coded	M	50	N3	<i>see separate code list</i>
714_06	Delivery quantity 1	M	53	N10,	<i>Delivery quantity in the unit of measurement of the purchase order with leading zeros, 3 decimal digits</i>
714_07	Masure unit code 1	M	66	A2	<i>see separate code list, left-justified entry.</i>
714_08	Delivery quantity 2	K	68	N10,	<i>Delivery quantity in the measurement unit of the supplier, right aligned with leading zeros, 3 decimal digits.</i>
714_09	Measure unit code 2	K	81	A2	<i>see separate code list, left justified entry</i>
714_10	VAT rate	K	83	N2,1	<i>Usage according to agreement in case of credit note procedure; right-justified entry with leading zeros; 1 decimal digit</i>
714_11	Empty 1	M	86	A1	<i>Filled with BLANKS</i>
714_12	Delivery note line item number	M	87	N3	<i>Position of a delivery note, right-justified entry with leading zeros; no decimal digits. Permitted range 001-999.</i>
714_13	Type of call-off, coded	K	90	A1	<i>see separate code list</i>
714_14	Batch number	K	91	A15	<i>Identification number that the supplier assigns to a batch.</i>
714_15	Usage code	M	106	A1	<i>see separate code list</i>
714_16	Dangerous goods code	K	107	A8	<i>Statement from the provision about the transportation of dangerous substances (GGVS). Position 107-110 = Class Position 111-112 = Number Position 113-114 = Letter</i>
714_17	Preference status	M	115	A1	<i>see separate code list</i>
714_18	Dutiable goods	M	116	A1	<i>Blank = no customs goods 1 = customs goods</i>
714_19	Empty 2	M	117	A1	<i>Filled with BLANKS</i>
714_20	Inventory status	M	118	A1	<i>Only for EDL-application procedure 35. Encoded form: Blank = free, 1 = locked, transfer each status</i>
714_21	Changed version code	M	119	A2	<i>Encoded form: 1. Position BLANK = without statements G = first regular delivery of changed part. one-time transfer. 2. Position BLANK = without statements T = the engineering change status must be transferred in the record type 716 item 03</i>
714_22	Original delivery note number	K	121	A8	<i>Only for EDL-application procedure 36. Reference for original delivery note number of</i>

DE	Data Element Name	St	P F	Data Element Description
				<i>supplier</i>

Structure description of record type

715

Version

03

Package information

n times per delivery note

DE	Data Element Name	St	P	F	Data Element Description
715_01	Record type	M	1	N3	<i>Constant "715"</i>
715_02	Version number	M	4	N2	<i>Entry = 03</i>
715_03	Customer's package type code	M	6	A22	<i>Identification number that the customer assigns to packaging. In case of one-way packaging or loaned packaging from third parties it can be agreed between the partners. For VDA standard codes see separate codelist.</i>
715_04	Supplier's package type code	M	28	A22	<i>Identification code that the supplier assigns to packaging.</i>
715_05	Number of packages	M	50	N13	<i>Number packaging each type. Right-justified entry with leading zeros, no decimal digit</i>
715_06	Delivery note line item no.	M	63	N3	<i>Content of the field shall be the position number of record type 714 that this packaging belongs to. Right-justified entry with leading zeros. If the packaging refers to all positions of the preceding delivery note number (record type 713), three zeros are to be entered</i>
715_07	Quantity per pack	K	66	N10,	<i>Actual quantity of item number in the packaging; right-justified entry with leading zeros; 3 decimal digits Quantity indication and quantity unit according to record type 714, item 07.</i>
715_08	Package number from	K	79	A9	<i>Unique package number assigned to the package. The number must not repeat itself within one year; left-justified entry.</i>
715_09	Package number to	K	88	A9	<i>As preceding. If this element is used, the number sequence between PACKAGE-NO FROM and PACKAGE NO TO must be numerically rising without gaps.</i>
715_10	Package dimensions	K	97	N12	<i>Indication in millimetres Position 97-100 length 101 - 104 width 105 - 108 height</i>
715_11	Stacking factor (maximum stackability)	K	109	N1	<i>Indication of permitted stacking ability of the unit specified in the packaging type Encoded form: 1 = single stackable</i>
715_12	Warehouse call-off number	K	110	A15	<i>Only with ESP usage: Number of inventory status with ESP Feedback with ESP to customer.</i>
715_13	Label indicator	K	125	A1	<i>Barcode identification of transport label (VDA 4902) in data element PACKAGE NUMBER. Valid entry (see also VDA 4902 description and VDA 4913 description under 2.2.4): G = Mixed package (with sub-packages and different item numbers) M = Master label (with sub-packages and same item numbers) S = Single label (1 package)</i>
715_14	Returnable package indicator	K	126	A1	<i>Valid entry: blank or M = reusable packaging</i>

DE	Data Element Name	St	P	F	Data Element Description
715_15	Property code	K	127	A1	<i>E = one-way packaging</i> <i>Indication only when using reusable packaging</i> <i>Valid entry: blank = undefined</i> <i>K = Reusable packaging property customer</i> <i>L = Reusable packaging property supplier returnable</i> <i>D = Reusable loaned packaging from third parties returnable</i>
715_16	Empty	M	128	A1	<i>Filled with BLANKS</i>

Structure description of record type

716

Version

02

Line item text

DE	Data Element Name	St	P	F	Data Element Description
716_01	Record type	M	1	N3	<i>Constant "716"</i>
716_02	Version number	M	4	N2	<i>Entry = 02</i>
716_03	Text 1	M	6	A40	<i>Text area that can be used for the unformatted transmission of information. If in the record type 714, item 21, a T is entered, the CONSTRUCTION CHANGE STATUS must be entered here (left-justified).</i>
716_04	Text 2	K	46	A40	<i>Text area that can be used for the unformatted transmission of information.</i>
716_05	Text 3	K	86	A40	<i>Text area that can be used for the unformatted transmission of information.</i>
716_06	Empty	M	126	A3	<i>Filled with BLANKS</i>

Structure description of record type 717 Version 01

Individual packaging data

*Once per package**Only used in EDL processes (external service provider)*

DE	Data Element Name	St	P	F	Data Element Description
717_01	Record	M	1	N3	<i>Constant "717"</i>
717_02	Version number	M	4	N2	<i>Entry = 02</i>
717_03	Individual package number	M	6	A15	
717_04	Delivery quantity 1	M	21	N10,	<i>Delivery quantity in the measure unit of the delivery instruction, with regard to the smallest unit, right-justified entry with leading zeros, 3 decimal digits</i>
717_05	Measure unit code	M	34	A2	<i>see separate code list</i>
717_06	Delivery quantity 2	K	36	N10,	<i>Delivery quantity in the measure unit of the supplier, with regard to the smallest unit, right aligned entry with leading zeros, 3 decimal digits</i>
717_07	Measure unit code 2	K	49	A2	<i>see separate code list</i>
717_08	Batch number	K	51	A15	<i>Identification number that the manufacturer assigns to a batch</i>
717_09	Empty	M	66	A63	<i>Filled with BLANK</i>

Structure description of record type
Production numbers

718

Version

02

DE	Data Element Name	St	P	F	Data Element Description
718_01	Record type	M	1	N3	<i>Constant "718"</i>
718_02	Version number	M	4	N2	<i>Entry = 02</i>
718_03	Delivery note number	M	6	N8	<i>Identification number that the supplier assigns to a delivery note. Right-justified entry with leading zeros.</i>
718_04	Manufacturing reference number 1	M	14	A10	<i>Production number 1 Product numbers table If this record type is used, at least the first table element must be filled. Production-related identification number of the final product at the customer, with which a unit of purchased parts is delivered. left-justified entry.</i>
718_05	Manufacturing reference number 2	K	24	A10	
718_06	Manufacturing reference number 3	K	34	A10	
718_07	Manufacturing reference number 4	K	44	A10	
718_08	Manufacturing reference number 5	K	54	A10	
718_09	Manufacturing reference number 6	K	64	A10	
718_10	Manufacturing reference number 7	K	74	A10	
718_11	Manufacturing reference number 8	K	84	A10	
718_12	Manufacturing reference number 9	K	94	A10	
718_13	Manufacturing reference number 10	K	104	A10	
718_14	Manufacturing reference number 11	K	114	A10	
718_15	Empty	M	124	A5	<i>Filled with BLANKS</i>

Structure description of record type
Trailer record despatch and transport data
Once per transmission

719 Version 02

DE	Data Element Name	St	P	F	Data Element Description
719_01	Record type	M	1	N3	<i>Constant "719"</i>
719_02	Version number	M	4	N2	<i>Entry = 02</i>
719_03	Record type counter 711	M	6	N7	<i>Number of transferred records of record type 711 Right-justified entry with leading zeros.</i>
719_04	Record type counter 712	M	13	N7	<i>Number of transferred records of record type 712 Right-justified entry with leading zeros.</i>
719_05	Record type counter 713	M	20	N7	<i>Number of transferred records of record type 713 Right-justified entry with leading zeros.</i>
719_06	Record type counter 714	M	27	N7	<i>Number of transferred records of record type 714 Right-justified entry with leading zeros.</i>
719_07	Record type counter 715	M	34	N7	<i>Number of transferred records of record type 715 Right-justified entry with leading zeros.</i>
719_08	Record type counter 716	M	41	N7	<i>Number of transferred records of record type 716 Right-justified entry with leading zeros.</i>
719_09	Record type counter 718	M	48	N7	<i>Number of transferred records of record type 718 Right-justified entry with leading zeros.</i>
719_10	Record type counter 719	M	55	N7	<i>Number of transferred records of record type 719 Right-justified entry with leading zeros.</i>
719_11	Record type counter 717	M	62	N7	<i>Number of transferred records of record type 717 Right-justified entry with leading zeros.</i>
719_12	Empty	M	69	A60	<i>Filled with BLANKS</i>

711_02		Version no.
Code	Name/Description	
03	Version 03	

711_11		Type of delivery, code
Code	Name/Description	
	Standard	
E	Express delivery	
J	JIT-delivery	

712_02		Version no.
Code	Name/Description	
03	Version 03	

712_10		Delivery terms, coded
Code	Name/Description	
01	Unpaid	
03	Paid	

712_14		Means of transport, coded
Code	Name/Description	
01	Licence plate	
02	Bordero number	
07	Express parcel number	
08	Rail-car number	
09	Mail-package number	
10	Flight no. and/or freight bill no.	
11	Name of ship	

712_16		Qualifier for information in record 712, field 17
Code	Name/Description	
1	Zip code In field 17 the zip code (of the street address) of the dispatching plant has to be entered for freight determination.	
2	Official licence plate of the transporting vehicle In field 17 the official licence plate of the transporting vehicle (towing vehicle) has to be entered. The entrance is only valid, if in field 14 the value 02 (for BORDERO-number) is entered.	

712_21		Truck type code
Code	Name/Description	

1	Standard truck with/without trailer
2	Semi-trailer
3	Greater area truck with/without trailer (Jumbo)
4	Greater area semi-trailer (Jumbo)

713_02	Version no.
Code	Name/Description

03	Version 03
----	------------

713_06	Dispatch type
Code	Name/Description

01	Sub supplier's truck
02	Customer's truck
03	Freight forwarder's truck
04	Railway company's truck
05	Supplier's own truck
08	Rail car
09	Mail delivery
10	Air freight
11	Sea freight
20	Private parcel service

713_09	Process code
Code	Name/Description

30	Entry message from EDL to supplier when EDL-application
32	Damage incurred during transit / Loss / Difference from EDL to supplier when EDL-application
33	Return from EDL to supplier when EDL-application
35	Stock from EDL to supplier and/or customer when EDL-application
36	Dispatch advice from EDL to Lieferant when EDL-application
40	Delivery advice when EDL-application - supplier to EDL - EDL to customer
	When direct data exchange between supplier and customer

714_02	Version number
Code	Name/Description

03	
----	--

714_05	Country of origin, coded
Code	Name/Description
000	Unknown
001	Frankreich
003	Niederlande
004	Deutschland
005	Italien
006	Vereinigtes Königreich
007	Irland
008	Dänemark
009	Griechenland
010	Portugal
011	Spanien
017	Belgien
018	Luxemburg
021	Ceuta
023	Melilla
024	Island
028	Norwegen
030	Schweden
032	Finnland
037	Liechtenstein
038	Österreich
039	Schweiz
041	Färöer
043	Andorra
044	Gibraltar
045	Vatikanstadt
046	Malta
047	San Marino
052	Türkei
053	Estland
054	Lettland
055	Litauen
060	Polen
061	Tschechische Republik
063	Slowakei

064	Ungarn
066	Rumänien
068	Bulgarien
070	Albanien
072	Ukraine
073	Belarus
074	Republik Moldau
075	Russische Föderation
076	Georgien
077	Armenien
078	Aserbaidshan
079	Kasachstan
080	Turkmenistan
081	Usbekistan
082	Tadschikistan
083	Kirgisische Republik
091	Slowenien
092	Kroatien
093	Bosnien und Herzegowina
095	Kosovo
096	Ehemalige jugoslawische Republik Mazedonien
097	Montenegro
098	Serbien
204	Marokko
208	Algerien
212	Tunesien
216	Libysch-Arabische Dschamahirija
220	Ägypten
224	Sudan
228	Mauretanien
232	Mali
236	Burkina Faso
240	Niger
244	Tschad
247	Kap Verde
248	Senegal
252	Gambia
257	Guinea-Bissau

260	Guinea
264	Sierra Leone
268	Liberia
272	Côte d'Ivoire
276	Ghana
280	Togo
284	Benin
288	Nigeria
302	Kamerun
306	Zentralafrikanische Republik
310	Äquatorialguinea
311	São Tomé und Príncipe
314	Gabun
318	Kongo
322	Kongo, demokratische Republik
324	Ruanda
328	Burundi
329	St. Helena
330	Angola
334	Äthiopien
336	Eritrea
338	Dschibuti
342	Somalia
346	Kenia
350	Uganda
352	Vereinigte Republik Tansania
355	Seychellen
357	Britisches Territorium im Indischen Ozean
366	Mosambik
370	Madagaskar
373	Mauritius
375	Komoren
377	Mayotte
378	Sambia
382	Simbabwe
386	Malawi
388	Südafrika
389	Namibia

391	Botsuana
393	Swasiland
395	Lesotho
400	Vereinigte Staaten
404	Kanada
406	Grönland
408	St. Pierre und Miquelon
412	Mexiko
413	Bermuda
416	Guatemala
421	Belize
424	Honduras
428	El Salvador
432	Nicaragua
436	Costa Rica
442	Panama
446	Anguilla
448	Kuba
449	St. Kitts und Nevis
452	Haiti
453	Bahamas
454	Turks- und Caicosinseln
456	Dominikanische Republik
457	Amerikanische Jungferninseln
459	Antigua und Barbuda
460	Dominica
463	Kaimaninseln
464	Jamaika
465	St. Lucia
467	St. Vincent und die Grenadinen
468	Britische Jungferninseln
469	Barbados
470	Montserrat
472	Trinidad und Tobago
473	Grenada
474	Aruba
478	Niederländische Antillen
480	Kolumbien

484	Venezuela
488	Guyana
492	Suriname
500	Ecuador
504	Peru
508	Brasilien
512	Chile
516	Bolivien
520	Paraguay
524	Uruguay
528	Argentinien
529	Falklandinseln (Malwinen)
600	Zypern
604	Libanon
608	Arabische Republik Syrien
612	Irak
616	Islamische Republik Iran
624	Israel
625	Besetzte palästinensische Gebiete
626	Timor-Leste
628	Jordanien
632	Saudi-Arabien
636	Kuwait
640	Bahrain
644	Katar
647	Vereinigte Arabische Emirate
649	Oman
653	Jemen
660	Afghanistan
662	Pakistan
664	Indien
666	Bangladesch
667	Malediven
669	Sri Lanka
672	Nepal
675	Bhutan
676	Myanmar
680	Thailand

684	Laos, demokratische Volksrepublik
690	Vietnam
696	Kambodscha
700	Indonesien
701	Malaysia
703	Brunei Darussalam
706	Singapur
708	Philippinen
716	Mongolei
720	China
724	Korea, demokratische Volksrepublik
728	Republik Korea
732	Japan
736	Taiwan
740	Hongkong
743	Macau
800	Australien
801	Papua-Neuguinea
803	Nauru
804	Neuseeland
806	Salomonen
807	Tuvalu
809	Neukaledonien
811	Wallis und Futuna
812	Kiribati
813	Pitcairinseln
815	Fidschi
816	Vanuatu
817	Tonga
819	Samoa
820	Nördliche Marianen
822	Französisch-Polynesien
823	Föderierte Staaten von Mikronesien
824	Marshallinseln
825	Palau
830	Amerikanisch-Samoa
831	Guam
832	Kleinere amerikanische Überseeinseln

833	Kokosinseln (Keelinginseln)
834	Weihnachtsinsel
835	Heard und McDonaldinseln
836	Norfolkinsel
837	Cookinseln
838	Niue
839	Tokelau
891	Antarktis
892	Bouvetinsel
893	Südgeorgien und die Südlichen Sandwichinseln
894	Französische Südgebiete
950	Schiffs- und Luftfahrzeugbedarf (Lieferung von Schiffs- und Luftfahrzeugbedarf auf fremde Schiffe und Luftfahrzeuge in deutschen (Flug-) Häfen)
951	Schiffs- und Luftfahrzeugbedarf (Lieferung von Schiffs- und Luftfahrzeugbedarf auf fremde Schiffe und Luftfahrzeuge in deutschen (Flug-) Häfen) im Rahmen des innergemeinschaftlichen Warenverkehrs
952	Schiffs- und Luftfahrzeugbedarf (Lieferung von Schiffs- und Luftfahrzeugbedarf auf fremde Schiffe und Luftfahrzeuge in deutschen (Flug-) Häfen) im Rahmen des Warenverkehrs mit Drittländern
999	Other Countries

714_07	
Masure unit code 1	
Code	Name/Description
KG	Kilogram
L	Litre
M	Metre
M2	Square metre
M3	Cubic metre
SA	Set
ST	Piece
T	Can

714_09	
Masure unit code 2	
Code	Name/Description
KG	Kilogram
L	Litre
M	Metre
M2	Square metre
M3	Cubic metre
SA	Set
ST	Piece

T	Can
714_13	
Type of call-off, coded	
Code	Name/Description
	Normal delivery
F	Daily call-off (according to the VDA-recommendation 4915)
P	Call-off in production sequence call-off (according to the VDA-recommendation 4916). When 'P' the related production numbers must be transmitted with record type 718.
714_15	
Usage code	
Code	Name/Description
E	General substitute
M	Substitute pattern
S	General series
U	Series and Substitute
714_17	
Preference status	
Code	Name/Description
C	Switzerland
F	Finland
G	Goods of EU origin; all countries with preferential agreement
I	Iceland
N	Norway
O	Austria
S	Sweden
W	Goods of EU origin; preferential agreement for goods transportation within the EFTA states
X	Not yet checked, no goods' origin
714_18	
Dutiable goods	
Code	Name/Description
1	Bonded goods
	No bonded goods
714_20	
Inventory status	
Code	Name/Description
1	Blocked, transfer per status
	Paid
715_02	
Version number	

715_03	
Customer's package type code	
Code	Name/Description
080607	VDA GLT 800 x 600 x 700
121010	VDA GLT 1200 x 1000 x 975
0000BEH	sonst. Flüssigkeitsbehälter, Gebinde, Kanister, Hobbock, Tank, Container, nicht näher spezifiziert
0000BLE	Sheet metal packaging, sheet metal coils, not specified
0000BUN	Bunches, not specified
0000FAS	Barrel, not specified
0000LOS	Loose material (unpacked)
0000PAL	120 x 80 cm, palette until 15 cm high
0000SAC	Bag, not specified
0000SCH	Box, case, package, not specified
0000SON	Additional packages, not specified
0000UMR	Hoop, tightening strap, not specified
0001PAL	120 x 80 cm, until 50 cm high
0001SCH	Box, case, package: Dimension until 30 x 20 x 14 cm
0001SON	Additional packages > 1 cbm, not specified
0002PAL	120 x 80 cm, palette until 100 cm high
0002SCH	Box, case, package: Dimension until 30 x 20 x 28 cm
0002SON	Additional packages < 1 cbm, not specified
0003PAL	120 x 80 cm, palette until 150 cm high
0003SCH	Box, case, package: Dimension until 40 x 30 x 14 cm
0004PAL	120 x 80 cm, palette until 200 cm high
0004SCH	Box, case, package: Dimension until 30 x 20 x 28 cm
0005PAL	120 x 100 cm, palette until 50 cm high
0005SCH	Box, case, package: Dimension until 50 x 30 x 20 cm
0006PAL	120 x 100 cm, palette until 100 cm high
0006SCH	Box, case, package: Dimension until 50 x 50 x 50 cm
0007PAL	120 x 100 cm, palette until 150 cm high
0007SCH	Box, case, package: Dimension until 58 x 48 x 36 cm
0008PAL	120 x 100 cm, palette until 200 cm high
0008SCH	Box, case, package: Dimension until 60 x 40 x 14 cm
0009PAL	Palette: 120 x 100 cm, Flachpalette bis 15 cm Höhe
0009SCH	Box, case, package: Dimension until 60 x 40 x 28 cm
0010PAL	Palette 160 x 120 x 15 cm

0010SCH	Box, case, package: Dimension until 80 x 60 x 40 cm
0011SCH	Box, case, package: Dimension until 98 x 58 x 36 cm
0012SCH	Box, case, package: Dimension until 100 x 60 x 73 cm
0013SCH	Box, case, package: Dimension until 120 x 78 x 110 cm
0014SCH	Box, case, package: Dimension until 120 x 80 x 40 cm
0015SCH	Box, case, package: Dimension until 120 x 80 x 90 cm
0016SCH	Box, case, package: Dimension until 120 x 100 x 90 cm
0017SCH	Schachtel, Kiste, Paket: Abmessung bis 160 x 120 x 90 cm
12081A	VDA KLT Ladeeinheit Abschlussdeckel 1200 x 800 x 84
12081AE	VDA KLT Ladeeinheit Abschlussdeckel 1200 x 800 x 84
1208A	VDA KLT Ladeeinheit Abschlussdeckel 1200 x 800 x 94
1208SP	VDA KLT Sicherungsplatte für Palette 1200 x 800
1210A	VDA KLT Ladeeinheit Abschlussdeckel 1200 x 1000 x 94
1210AE	VDA KLT Ladeeinheit Abschlussdeckel 1200 x 1000 x 94
13L	EWPS Zwischenlage 13 Zoll beschichtet
13S	EWPS Zwischenlage 13 Zoll unbeschichtet
14L	EWPS Zwischenlage 14 Zoll beschichtet
14S	EWPS Zwischenlage 14 Zoll unbeschichtet
15L	EWPS Zwischenlage 15 Zoll beschichtet
15S	EWPS Zwischenlage 15 Zoll unbeschichtet
16L	EWPS Zwischenlage 16 Zoll beschichtet
16S	EWPS Zwischenlage 16 Zoll unbeschichtet
175S	EWPS Zwischenlage 17.5 Zoll unbeschichtet
175SDC	EWPS Zwischenlage 17.5 Zoll unbeschichtet Steilschulter
17L	EWPS Zwischenlage 17 Zoll beschichtet
17S	EWPS Zwischenlage 17 Zoll unbeschichtet
18L	EWPS Zwischenlage 18 Zoll beschichtet
18S	EWPS Zwischenlage 18 Zoll unbeschichtet
195SDC	EWPS Zwischenlage 19.5 Zoll unbeschichtet Steilschulter
19L	EWPS Zwischenlage 19 Zoll beschichtet
19S	EWPS Zwischenlage 19 Zoll unbeschichtet
1BP	EWPS Grundpalette Größe 1
1TP	EWPS Abschlussrahmen Größe 1
20L	EWPS Zwischenlage 20 Zoll beschichtet
20S	EWPS Zwischenlage 20 Zoll unbeschichtet
20STBS	EWPS Zwischenlage 20 Zoll unbeschichtet Schrägschulter
21L	EWPS Zwischenlage 21 Zoll beschichtet
21S	EWPS Zwischenlage 21 Zoll unbeschichtet

225SDC	EWPS Zwischenlage 22.5 Zoll unbeschichtet Steilschulter
22L	EWPS Zwischenlage 22 Zoll beschichtet
22S	EWPS Zwischenlage 22 Zoll unbeschichtet
2BP	EWPS Grundpalette Größe 2
2TP	EWPS Abschlussrahmen Größe 2
3115RE	VDA R KLT ESD300 x 200 x 147
3115RLE	VDA RL KLT ESD 300 x 200 x 147
3147RL	VDA RL KLT 300 x 200 x 147
31DE	VDA KLT Deckel ESD 300 x 200
3214C	VDA C KLT 300 x 200 x 147
3215R	VDA R KLT 300 x 200 x 147
3217C	VDA C KLT 300 x 200 x 174
35D	VDA KLT Deckel 300 x 200
3715RF	VDA R KLT 300 x 200 x 147 mit RFID (Retrofit)
3747RLF	VDA RL KLT 300 x 200 x 147 mit RFID (Retrofit)
3BP	EWPS Grundpalette Größe 3
3TP	EWPS Abschlussrahmen Größe 3
4047RLE	VDA RL KLT ESD 400 x 300 x 147
4080RLE	VDA RL KLT ESD 400 x 300 x 280
4115RE	VDA R KLT ESD 400 x 300 x 147
4129RE	VDA R KLT ESD 400 x 300 x 280
4147RL	VDA RL KLT 400 x 300 x 147
41DE	VDA KLT Deckel ESD 400 x 300
4280RL	VDA RL KLT 400 x 300 x 280
4314C	VDA C KLT 400 x 300 x 147
4315R	VDA R KLT 400 x 300 x 147
4317C	VDA C KLT 400 x 300 x 174
4321C	VDA C KLT 400 x 300 x 214
4328C	VDA C KLT 400 x 300 x 280
4329R	VDA R KLT 400 x 300 x 280
45D	VDA KLT Deckel 400 x 300
4713RLF	VDA RL KLT 400 x 300 x 213 mit RFID (Retrofit)
4715RF	VDA R KLT 400 x 300 x 147 mit RFID (Retrofit)
4722RF	VDA R KLT 400 x 300 x 213 mit RFID (Retrofit)
4729RF	VDA R KLT 400 x 300 x 280 mit RFID (Retrofit)
4747RLF	VDA RL KLT 400 x 300 x 147 mit RFID (Retrofit)
4780RLF	VDA RL KLT 400 x 300 x 280 mit RFID (Retrofit)
4BP	EWPS Grundpalette Größe 4

4TP	EWPS Abschlussrahmen Größe 4
6047RLE	VDA RL KLT ESD 600 x 400 x 147
6080RLE	VDA RL KLT ESD 600 x 400 x 280
6115RE	VDA R KLT ESD 600 x 400 x 147
6129RE	VDA R KLT ESD 600 x 400 x 280
6147RL	VDA RL KLT 600 x 400 x 147
61DE	VDA KLT Deckel ESD 600 x 400
6280RL	VDA RL KLT 600 x 400 x 280
6410F	VDA F KLT 600 x 400 x 280 (94.5)
6414C	VDA C KLT 600 x 400 x 147
6415R	VDA R KLT 600 x 400 x 147
6417C	VDA C KLT 600 x 400 x 174
6421C	VDA C KLT 600 x 400 x 214
6428C	VDA C KLT 600 x 400 x 280
6429R	VDA R KLT 600 x 400 x 280
65D	VDA KLT Deckel 600 x 400
6713RLF	VDA RL KLT 600 x 400 x 213 mit RFID (Retrofit)
6715RF	VDA R KLT 600 x 400 x 147 mit RFID (Retrofit)
6722RF	VDA R KLT 600 x 400 x 213 mit RFID (Retrofit)
6729RF	VDA R KLT 600 x 400 x 280 with RFID (Retrofit)
6747RLF	VDA RL KLT 600 x 400 x 147 mit RFID (Retrofit)
6780RLF	VDA RL KLT 600 x 400 x 280 mit RFID (Retrofit)
COPACK	Virtuelle Verpackung
UNPACKD	unverpackte Ware (lose oder Schüttgut)

715_13		Label indicator
Code	Name/Description	
G	Mixed packages (with sub-packages and different reference numbers)	
M	Master-Label (with sub-packages and the same reference numbers)	
S	Single-Label (1 package)	

715_14		Returnable package indicator
Code	Name/Description	
E	One way packaging	
M	Returnable packaging	

715_15		Property code
Code	Name/Description	
D	Returnable packaging belonging to 3rd party, must be returned	

K Returnable packaging property of customer

L Returnable packaging, property of supplier, must be returned

716_02 Version number	
Code	Name/Description
02	Version 02

718_02 Version number	
Code	Name/Description
02	

719_02 Version number	
Code	Name/Description
02	Version 02
